



MODEL:

Delabie DLB-756MCH

# DELABIE



Delabie BINOPTIC mixer tap – MAINS supply model

**Accreditation:** WRAS  
**Controls:** Mains supply  
**Mount:** Deck mounted  
**Tap Type:** Binoptic Mixer

### FEATURES & BENEFITS

- WRAS approved.
- Independent IP65 electronic control unit.
- 230/12V mains supply with transformer.
- 15mm connector for compression fittings.
- Flow rate pre-set at 3 lpm at 3 bar, can be adjusted from 1.5 to 6 lpm.
- Scale resistant flow straightener.
- Adjustable duty flush (pre-set flush ~60 sec. every 24hr after last use).
- Active, infrared presence detection, sensor at the end of the spout optimises detection.
- Chrome-plated brass body.
- PEX flexible with filter and solenoid valve.
- Reinforced fixing.
- Anti-blocking safety.
- Spout with smooth interior and low volume of water (reduces bacterial niches).
- Side temperature control with adjustable maximum temperature limiter.

### TECHNICAL INFO

- Connection(s): M $\frac{1}{2}$ -inch.
- Drop height: 110mm.
- Spout length: 135mm.
- Flow rate: 3 lpm.

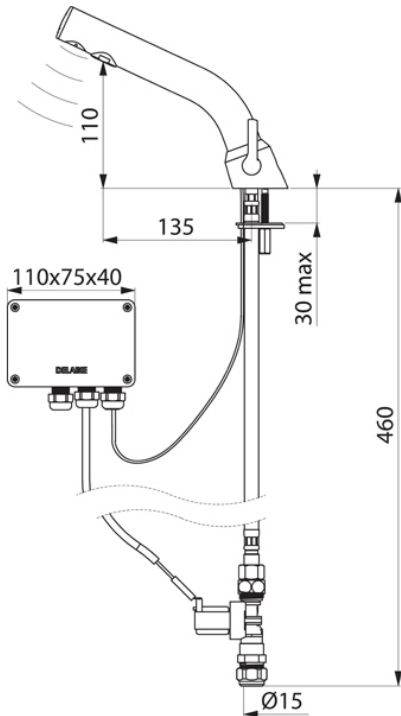

Dimensions are in millimeters. If a Cad file is required please visit [www.mechline.com](http://www.mechline.com).



MECHLINE DEVELOPMENTS LIMITED

Tel: +44 (0)1908 261511 | Email: [info@mechline.com](mailto:info@mechline.com) | Web: [www.mechline.com](http://www.mechline.com)