



MODEL:

CaterTap 500MM

CATERTAP

½-inch Single Monobloc Dome Head Mixer with 8-inch low profile spout

FEATURES & BENEFITS

- Includes flexible tap tails and non-return valves
- High-grade chrome finished
- Low maintenance and long lasting
- Manufactured to British Standards
- Robust commercial tap
- 8-inch low profile spout

TECHNICAL INFO

- Flow rate: 12 lpm at 3 bar pressure
- Connection(s): ½-inch Male thread or ¾-inch Female thread

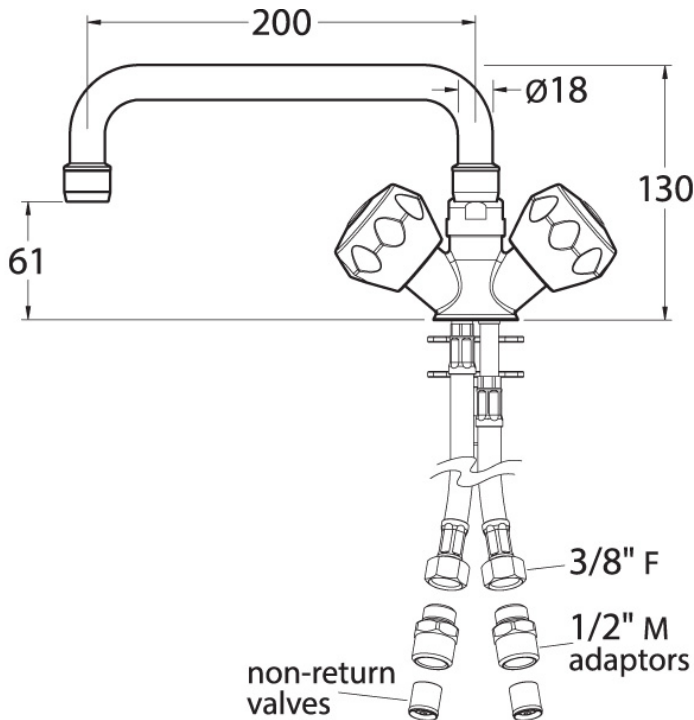

Dimensions are in millimeters. If a Cad file is required please visit www.mechline.com.



MECHLINE DEVELOPMENTS LIMITED

Tel: +44 (0)1908 261511 | Email: info@mechline.com | Web: www.mechline.com